

COVENANT SHORES DOCK REPAIR

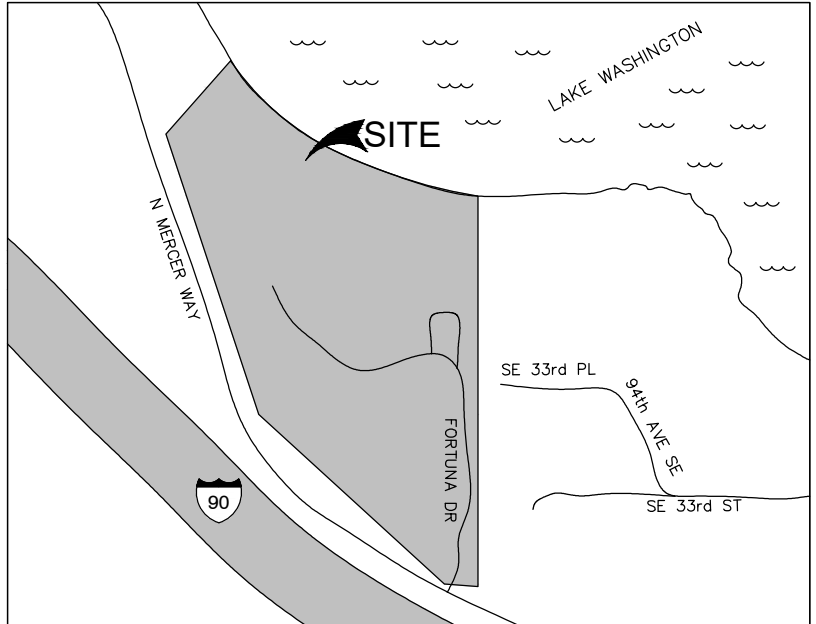

VICINITY MAP

NOT TO SCALE

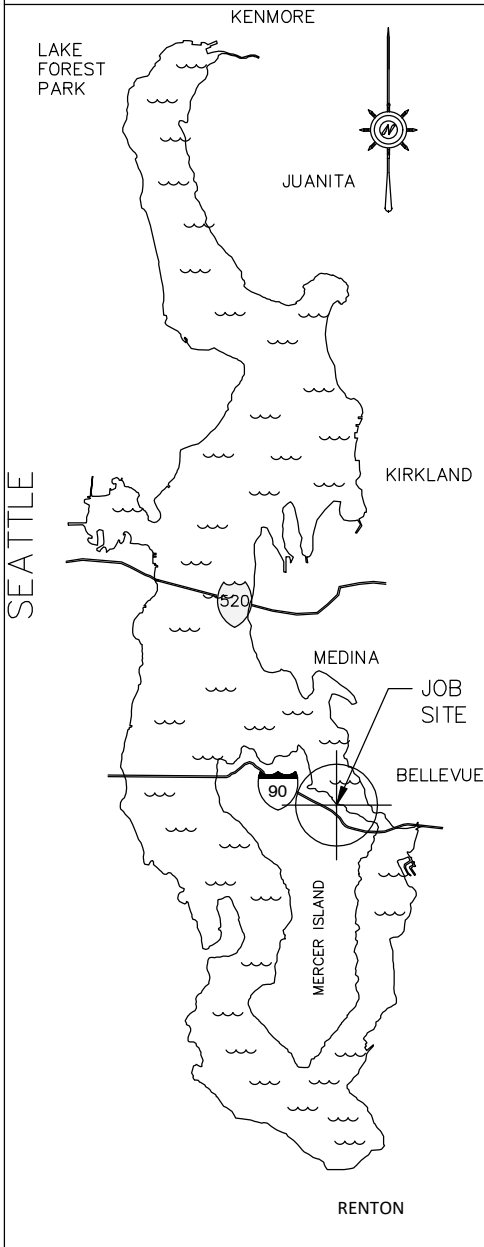
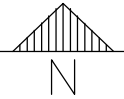

1/4 SEC: SE-7-24-5

LAT: 47.58158

LONG: -122.21539

DECIMAL CONVERSION:

LAT: 47°34'53.688"

LONG: -122°12'55.4034"

LEGAL DESCRIPTION:

(PARCEL No. 0724059016)

POR OF GL 4 & LOTS 24 & 25 SUNNYBANK ADD DAF - BEG 658 FT N & 826 FT W OF SE COR GL 4 TH S 00-10-12 E TO NLY MGN N MERCER WAY & TPOB TH N 00-10-12 W TO SH LN LK WASH TH N 75-16-00 W 103.49 FT TH S 87-36-00 W 100.60 FT TH N 67-33-00 W 111.66 FT TH N 52-10-00 W 100.65 FT TH N 56-26-00 W 100.08 FT TH N 40-43-00 W 107.71 FT TH N 32-08-00 W 66.66 FT TO NW COR LOT 24 SUNNYBANK TH S 41-23-31 W 252.293 FT TO NELY MGN MERCER WAY TH SELY ALG SD NELY MGN TO TPOB TGW SH LDS ADJ AKA POR MI LL REVISION 89-03-04 REC #8905119011 "PORTION TAXABLE"

SHEET INDEX:

1. COVER PAGE
2. EXISTING SITE PLAN
3. EXISTING PLAN VIEW
4. PROPOSED PLAN VIEW
5. EXISTING FRAMING PLAN
6. PROPOSED FRAMING PLAN
7. EXISTING/PROPOSED ELEVATION VIEWS
8. SECTION DETAILS
9. SECTION DETAIL

10. CONSTRUCTION DETAILS
11. MITIGATION PLANTING PLAN.

PAGE 1 of 11

APPLICANT: COVENANT SHORES INC.
 SITE ADD. 9105 FORTUNA DRIVE
 MERCER ISLAND, WA 98040
 MAIL ADD. SAME AS ABOVE
 PAGE: 1 OF 11 DATE: 01/16/23

ADJACENT OWNERS:
 ① CITY OF MERCER ISLAND
 N MERCER WAY
 ② SMITH GREER-TTEE
 9202 SE 33RD ST
 LOCAL JURISDICTION:
 CITY OF MERCER ISLAND

PROPOSED: REPAIR THE EXISTING PIER BY REMOVING AND REPLACING THE EXISTING DECKING WITH THRU-FLOW LEGACY PLASTIC GRATED DECKING.
 PURPOSE: MARINA MAINTENANCE
 DATUM: C.O.E



MARINE RESTORATION & CONSTRUCTION LLC

P.O. BOX 208, FALL CITY, WA 98024
 PHONE: (425) 576-8661

THIS DRAWING IS PROPERTY OF MARINE RESTORATION & CONSTRUCTION LLC AND MAY NOT BE COPIED OR REPRODUCED WITHOUT WRITTEN CONSENT

NOTE:

Property information for this site was obtained from survey. Marine Restoration & Construction LLC has added information from other sources including field measurements and aerial photos. We are not surveyors and can not guarantee great level of accuracy.

PARCEL 8106100230
N MERCER WAY
CITY OF MERCER ISLAND

PARCEL 4139300305
9202 SE 33RD ST
SMITH GREER-TTEE

PARCEL 0724059016
9105 FORTUNA DRIVE
COVENANT SHORES

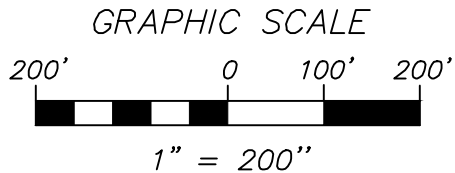
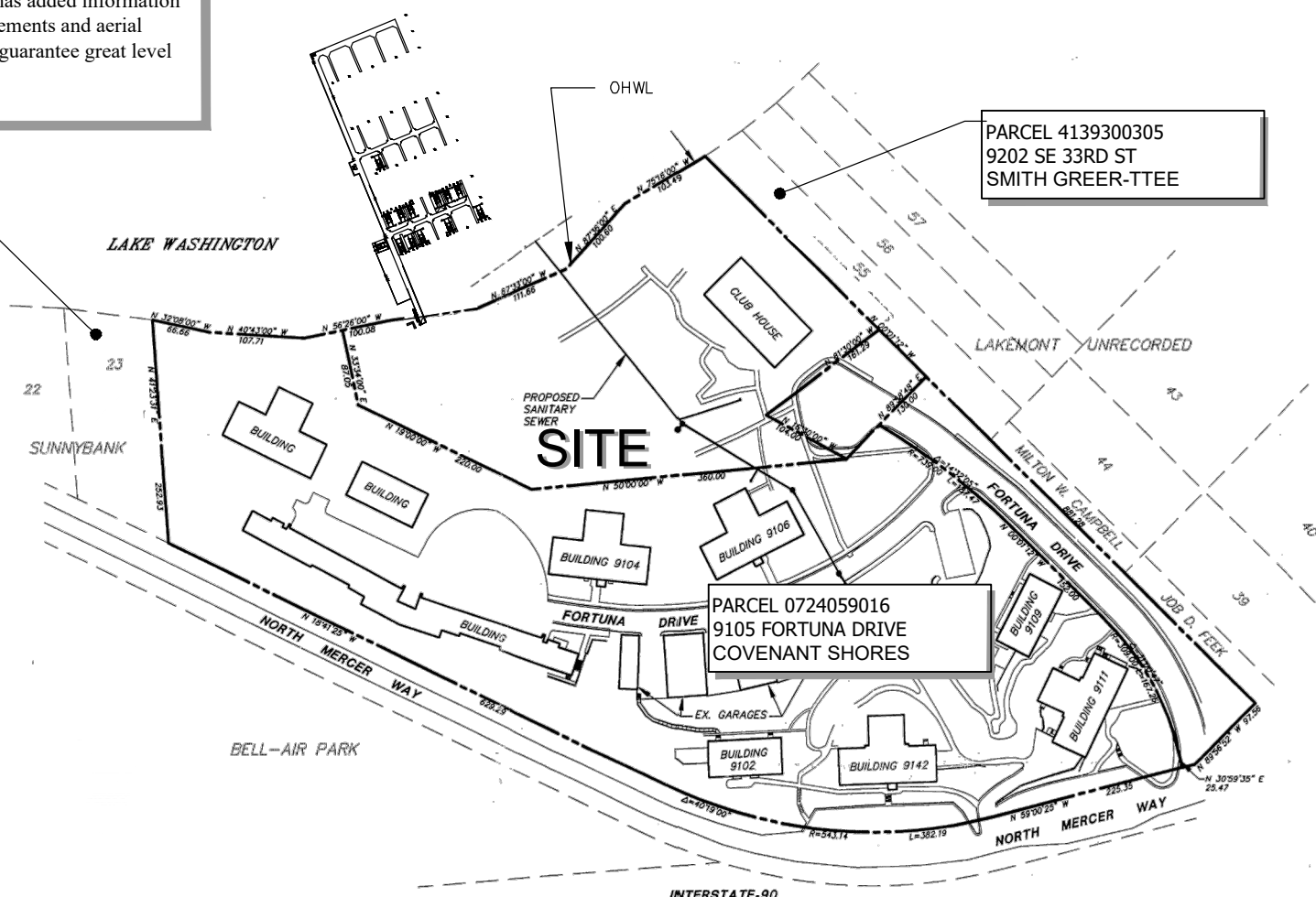

EXISTING SITE PLAN
SCALE: 1" = 200'



PLOT DATE: 21 January, 2023



MARINE RESTORATION & CONSTRUCTION LLC

MAIL: P.O. BOX 208, FALL CITY, WA 98024
PHONE: (425) 576-8661

THIS DRAWING IS PROPERTY OF MARINE RESTORATION & CONSTRUCTION LLC AND MAY NOT BE COPIED OR REPRODUCED WITHOUT WRITTEN CONSENT

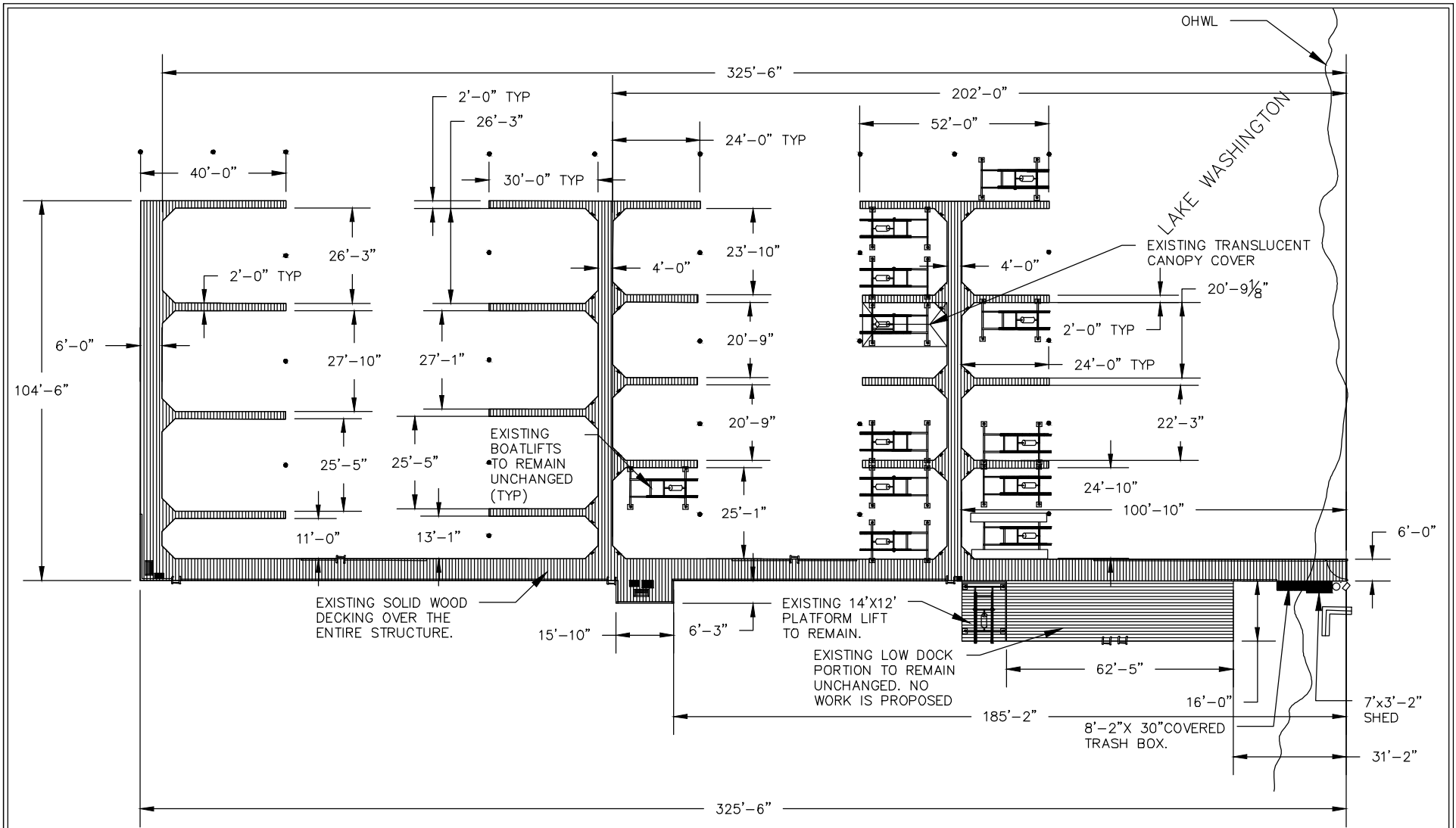

GRAPHIC SCALE

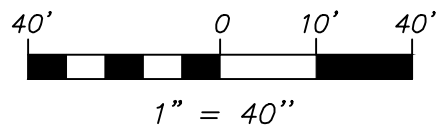

EXISTING PLAN VIEW
SCALE: 1" = 40'

- NOTES:**
- EACH SLIP HAS ELECTRICAL AND WATER SUPPLIES TO REMAIN.
 - 7 EXISTING ALUMINUM SWIM LADDERS TO REMAIN.
 - ALL FIRE EXTINGUISHER STORAGE BOXES TO REMAIN.
 - ALL BOATLIFTS TO REMAIN UNCHANGED.
 - ALL BENCHES (2) TO REMAIN UNCHANGED.
 - ALL MOORING PILING TO REMAIN UNCHANGED (27).
 - ALL CHAMFERS ARE 43".
 - ALL EXISTING ALUMINUM CLEATS TO REMAIN.

PLOT DATE: 21 January 2023



MARINE RESTORATION & CONSTRUCTION LLC

MAIL: P.O. BOX 208, FALL CITY, WA 98024
PHONE: (425) 576-8661

THIS DRAWING IS PROPERTY OF MARINE RESTORATION & CONSTRUCTION LLC AND MAY NOT BE COPIED OR REPRODUCED WITHOUT WRITTEN CONSENT

WORK DESCRIPTION:

REMOVE EXISTING SOLID WOOD DECKING (4609 SQ. FT.) INSTALL INTERMEDIATE STRINGERS TO SUPPORT GRATED DECKING. INSTALL LEGACY THRU-FLOW PLASTIC GRATED DECKING OVER THE ENTIRE PIER (4609 SQ. FT.).

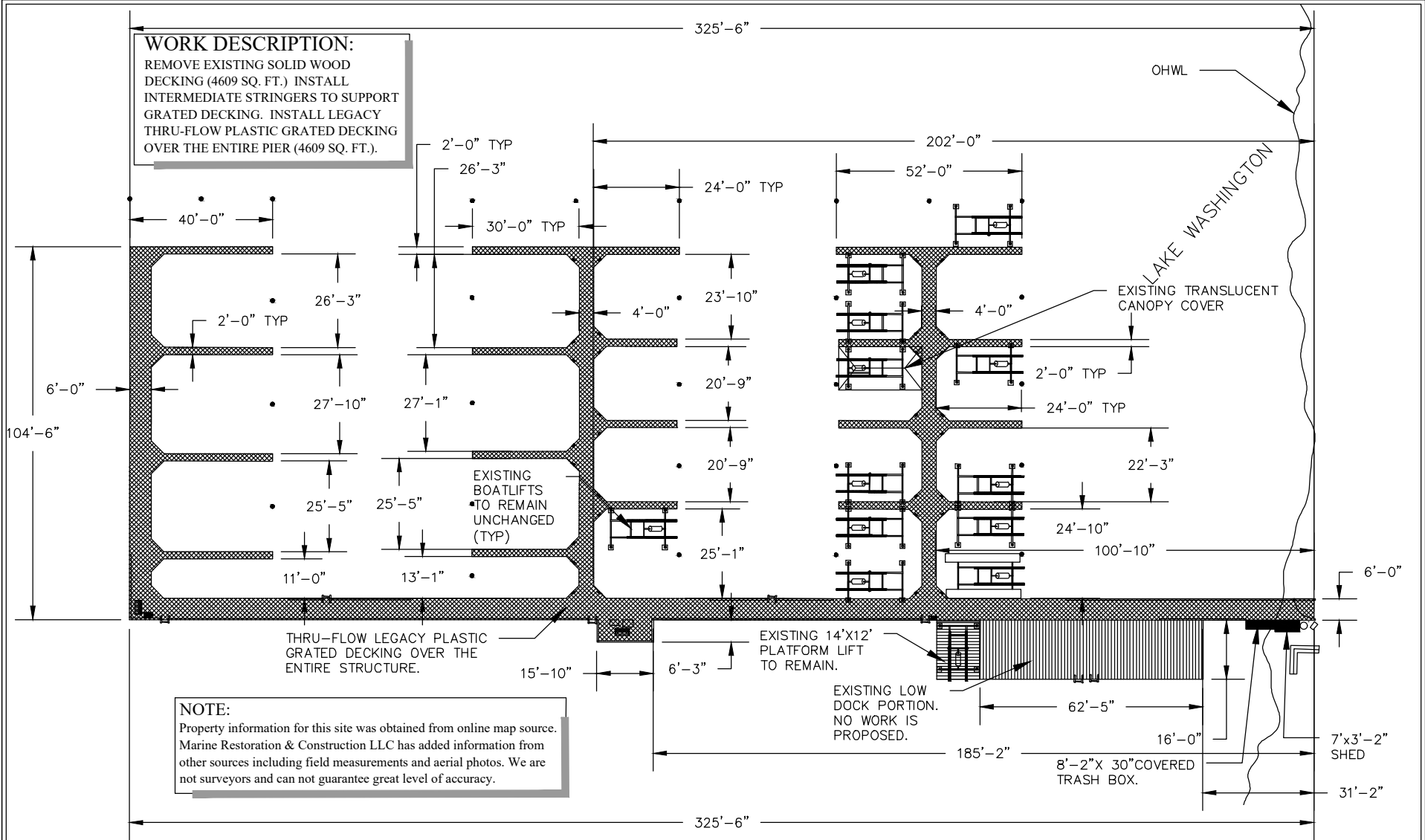

NOTE:

Property information for this site was obtained from online map source. Marine Restoration & Construction LLC has added information from other sources including field measurements and aerial photos. We are not surveyors and can not guarantee great level of accuracy.

GRAPHIC SCALE

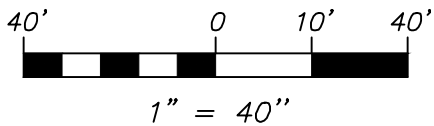

PROPOSED PLAN VIEW

SCALE: 1" = 40'



MARINE RESTORATION & CONSTRUCTION LLC

MAIL: P.O. BOX 208, FALL CITY, WA 98024
PHONE: (425) 576-8661

THIS DRAWING IS PROPERTY OF MARINE RESTORATION & CONSTRUCTION LLC AND MAY NOT BE COPIED OR REPRODUCED WITHOUT WRITTEN CONSENT

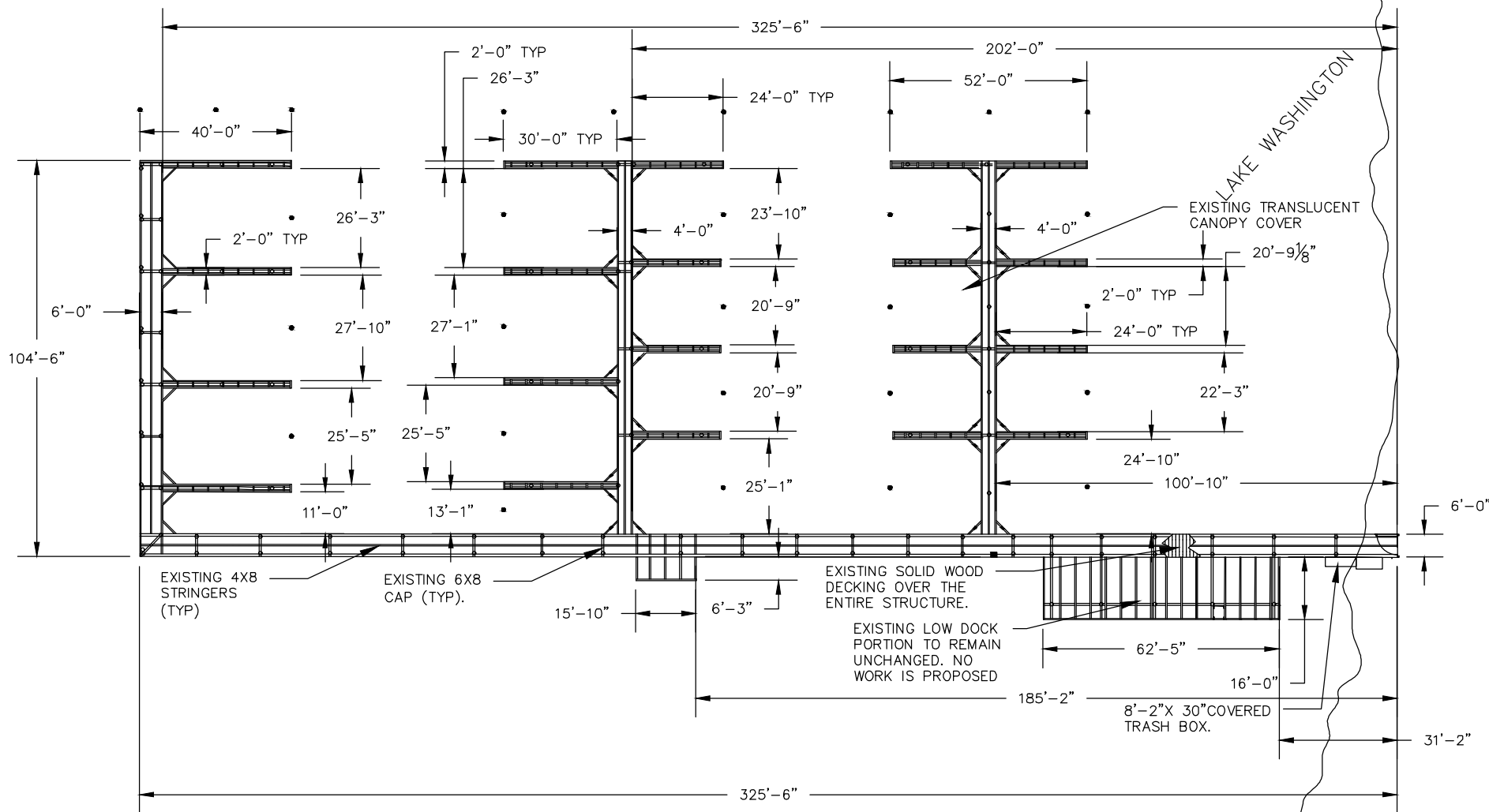

GRAPHIC SCALE

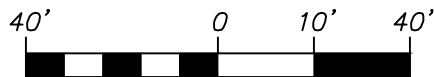

1" = 40"

EXISTING FRAMING PLAN

SCALE: 1" = 40'



MARINE RESTORATION & CONSTRUCTION LLC

MAIL: P.O. BOX 208, FALL CITY, WA 98024
 PHONE: (425) 576-8661

THIS DRAWING IS PROPERTY OF MARINE RESTORATION & CONSTRUCTION LLC AND MAY NOT BE COPIED OR REPRODUCED WITHOUT WRITTEN CONSENT

WORK DESCRIPTION:

REMOVE EXISTING SOLID WOOD DECKING (4609 SQ. FT.) INSTALL INTERMEDIATE STRINGERS TO SUPPORT GRATED DECKING. INSTALL LEGACY THRU-FLOW PLASTIC GRATED DECKING OVER THE ENTIRE PIER (4609 SQ. FT.)

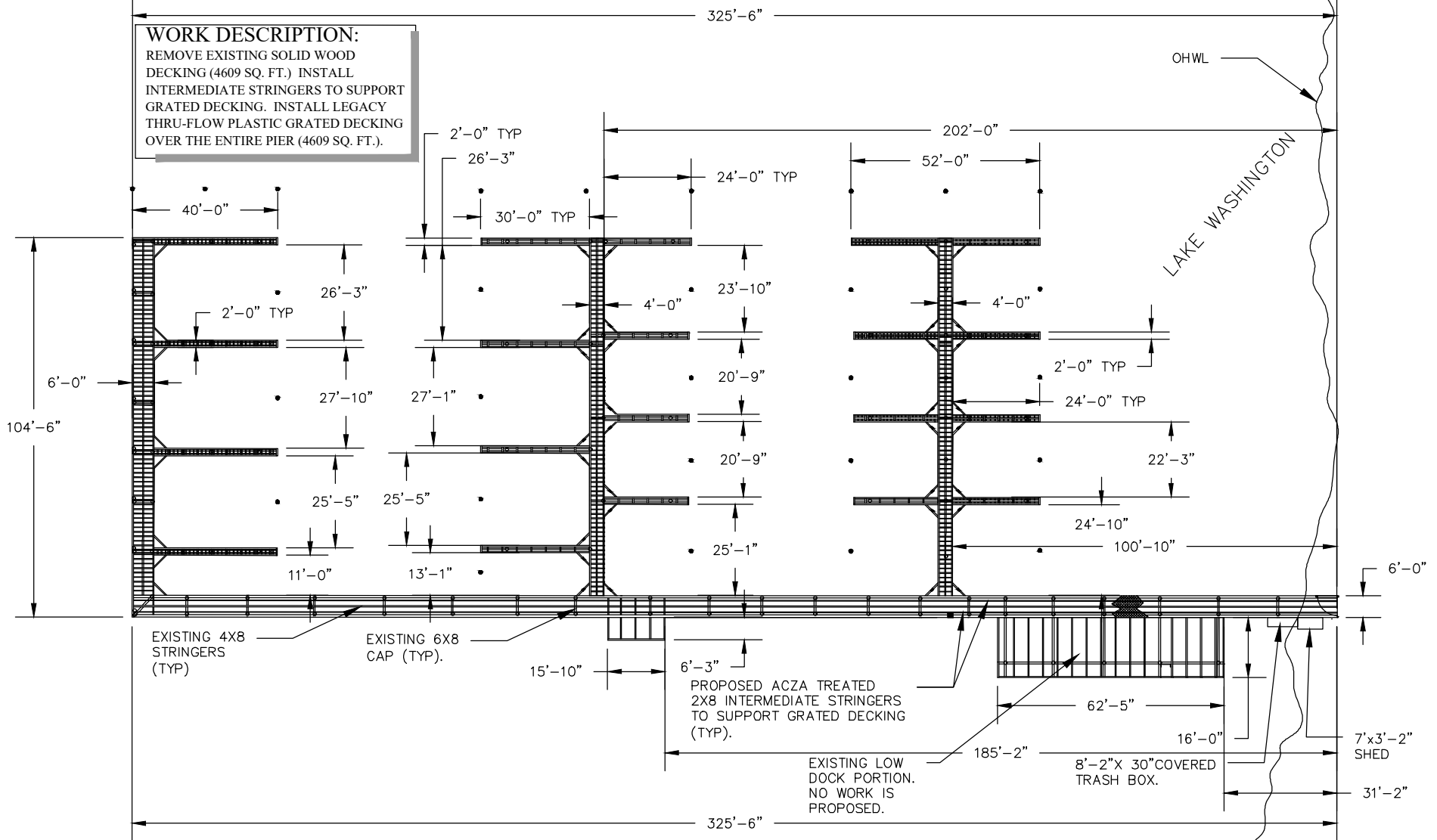

GRAPHIC SCALE

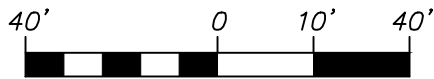

1" = 40"

PROPOSED FRAMING PLAN

SCALE: 1" = 40'



MARINE RESTORATION & CONSTRUCTION LLC

MAIL: P.O. BOX 208, FALL CITY, WA 98024
 PHONE: (425) 576-8661

THIS DRAWING IS PROPERTY OF MARINE RESTORATION & CONSTRUCTION LLC AND MAY NOT BE COPIED OR REPRODUCED WITHOUT WRITTEN CONSENT

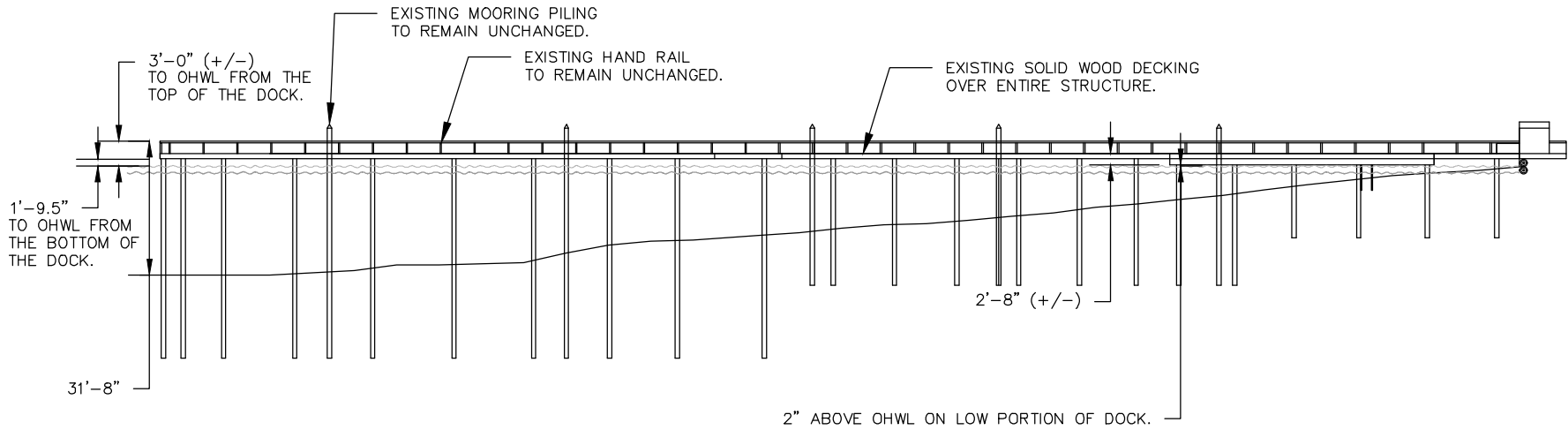

EXISTING ELEVATION VIEW

SCALE: 1" = 40'

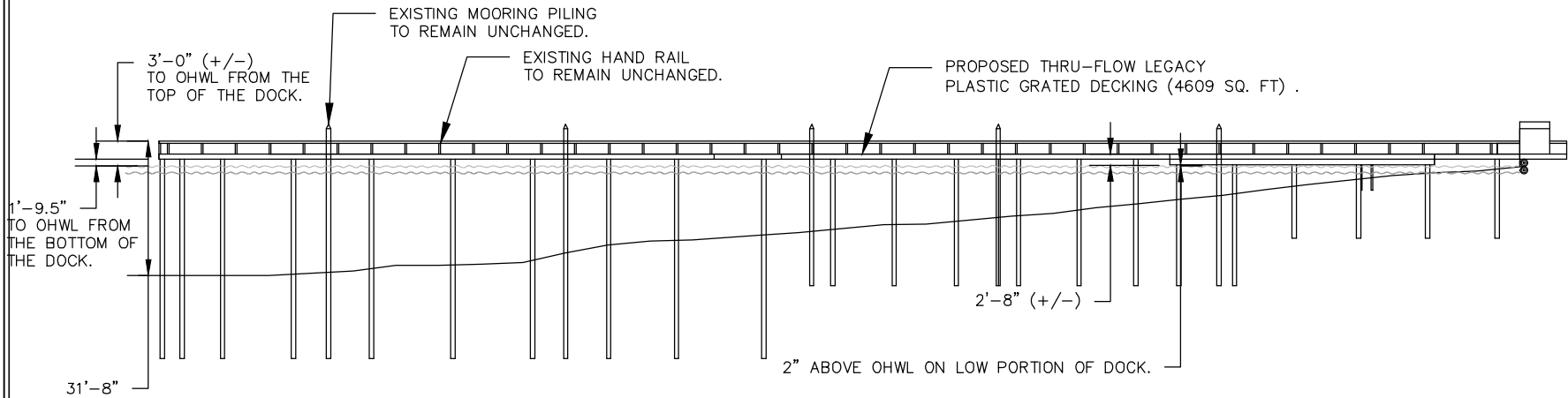

PROPOSED ELEVATION VIEW

SCALE: 1" = 40'



MARINE RESTORATION & CONSTRUCTION LLC

MAIL: P.O. BOX 208, FALL CITY, WA 98024
 PHONE: (425) 576-8661

THIS DRAWING IS PROPERTY OF MARINE RESTORATION & CONSTRUCTION LLC AND MAY NOT BE COPIED OR REPRODUCED WITHOUT WRITTEN CONSENT

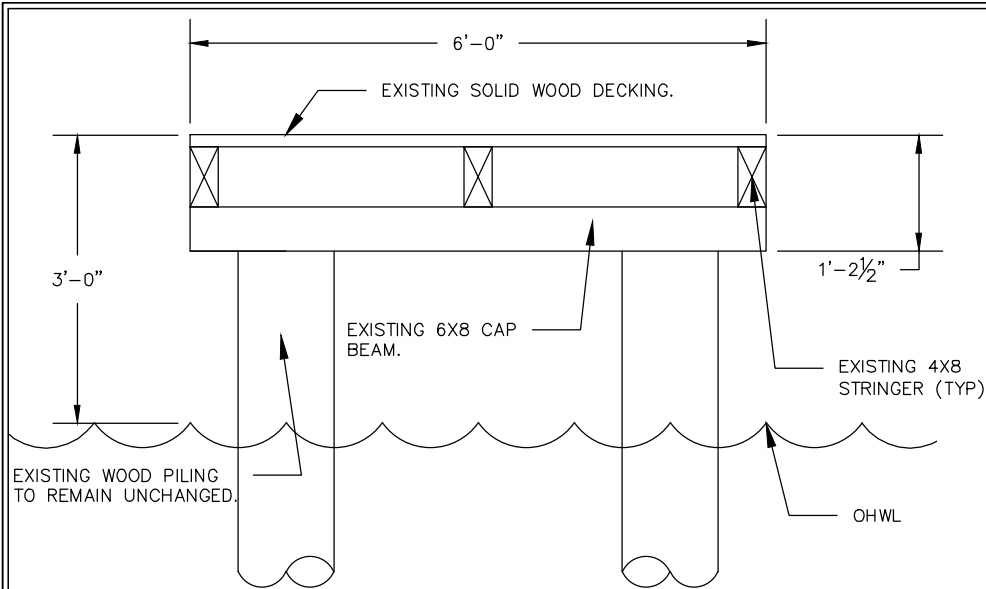

EXISTING MAIN WALKWAY SECTION DETAIL

SCALE: 1/4" = 1'-0"

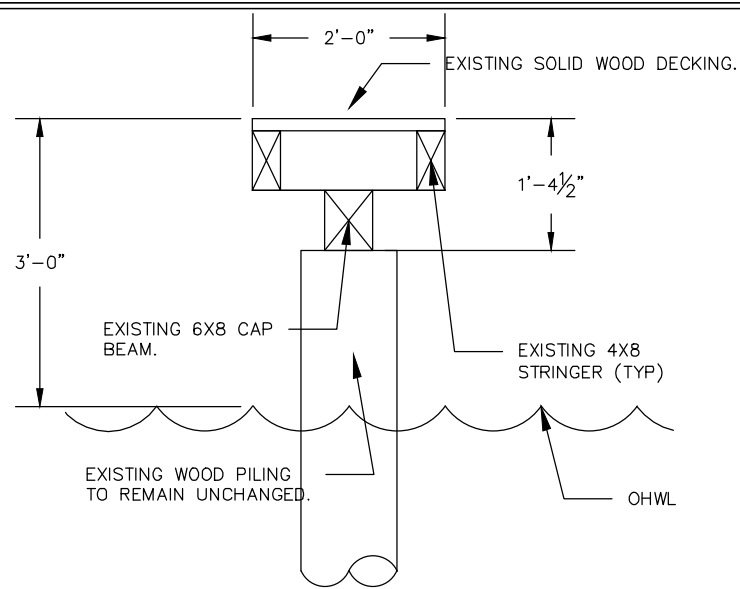

EXISTING FINGER SECTION DETAIL

SCALE: 1/4" = 1'-0"

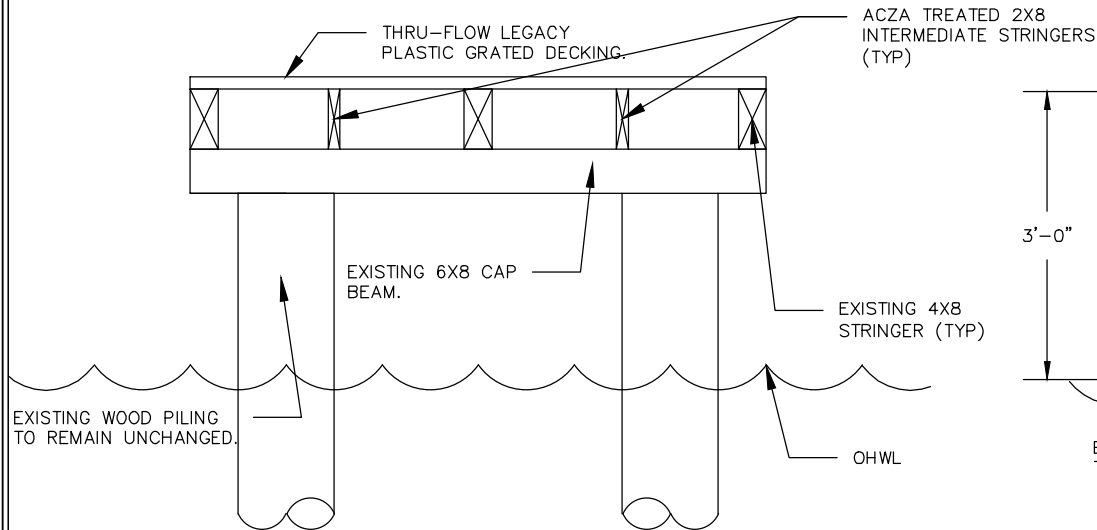

PROPOSED MAIN WALKWAY SECTION DETAIL

SCALE: 1/4" = 1'-0"

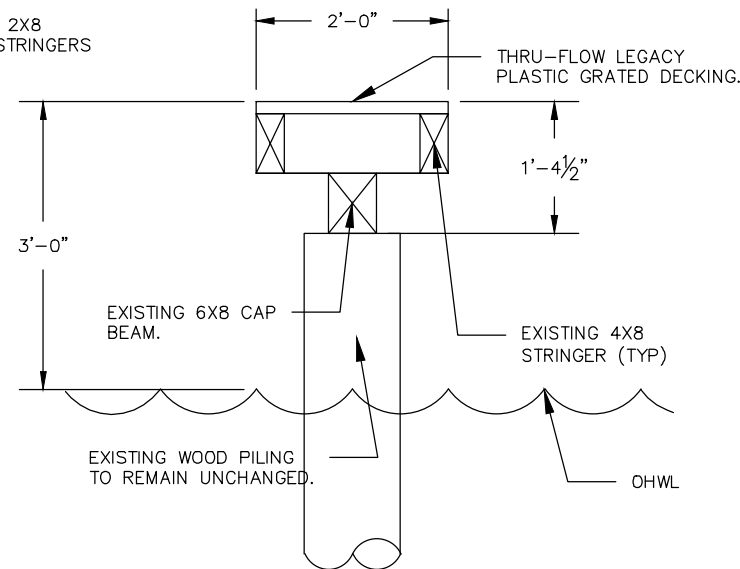

PROPOSED FINGER SECTION DETAIL

SCALE: 1/4" = 1'-0"



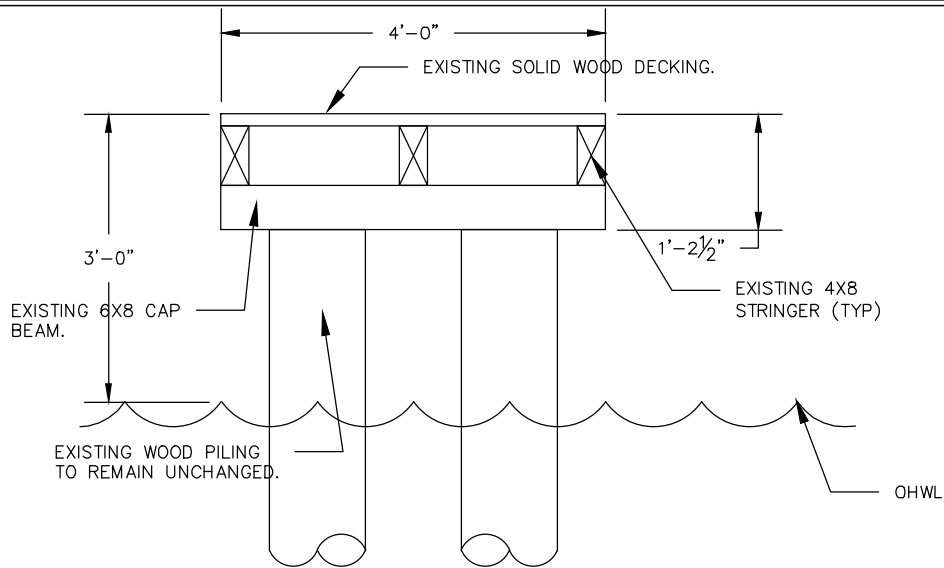

EXISTING ELLWALKWAY SECTION DETAIL

SCALE: 1/4" = 1'-0"

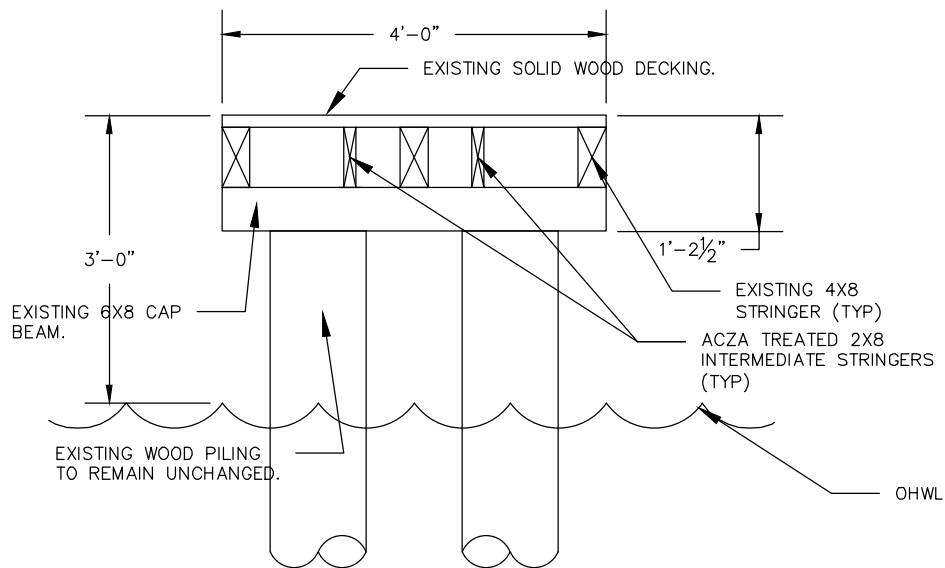

PROPOSED ELLWALKWAY SECTION DETAIL

SCALE: 1/4" = 1'-0"



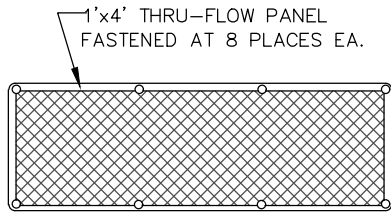

48" THRU-FLOW GRATED PANEL

N.T.S.

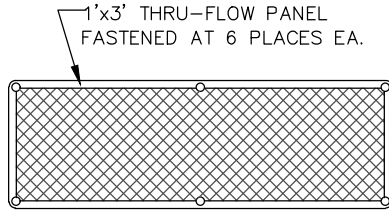

36" THRU-FLOW GRATED PANEL

N.T.S.

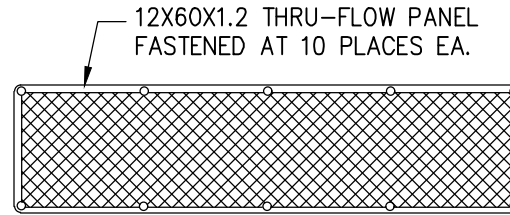

60" THRU-FLOW GRATED PANEL

N.T.S.

STAINLESS STEEL SCREW

1/2" GALVANIZED DRIFT PIN (USED ABOVE OHWL ONLY)

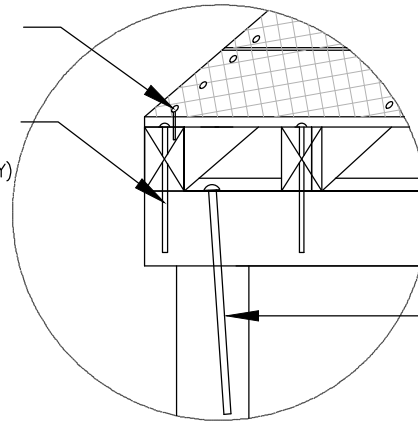

3/4"x18" GALVANIZED DRIFT PIN DOWN AT AN ANGLE (USED ABOVE OHWL ONLY)

CONNECTION DETAIL

N.T.S.

